

# MOTORIZED BENDING

MACHINES FOR THE ENTIRE RANGE OF  
TOP-QUALITY SHEET METAL WORKING



# WE TRULY GO THE DISTANCE TO HELP YOU GET AHEAD

PIONEERING SPIRIT AND INNOVATION.  
BORN OF PASSION FOR THE SHEET METAL TRADE.

## WE PLACE A HIGH PRIORITY ON THE SUCCESS OF OUR CUSTOMERS

At Schechtel, we aim to find ideas and solutions that make life easier for those who work in the sheet metal trade.

And it's been this way from the very beginning. Since then, this aspiration has given rise to numerous innovations: from the invention of bending technology to mobile data transfer for finished profiles.

Founded in 1910 as a simple blacksmith shop and guided by loads of pioneering spirit, Schechtel now ranks among the world's leading manufacturers of bending machines and shears for the processing of thin metal sheets.

## THANK YOU FOR YOUR CONFIDENCE

Very high quality, incredible durability, and outstanding reliability – that's what generations of clients in Germany and abroad have said about our products. While we're extremely honored by these words, they also motivate us to keep our standard of quality at a high level.

That's why we not only invest in technology, but also in creating an atmosphere of positivity and trust, as well as in the knowledge of our employees. Because, ultimately, the thing that truly helps a business get ahead is the commitment and competence of the people who determine its path. Satisfied employees are more committed, a fact that our customers can observe daily.

## LOYALTY COUNTS

We take our seal of quality ("Made in Germany") very seriously. We produce and assemble all of our machine parts exclusively in Germany. Our commitment to our location is also particularly evident in our longstanding close ties to partners and suppliers in the region.

Schechtel is a family business, owner-operated for over 100 years and now in its fourth generation.

A combination of healthy growth and strong economic stability means that our corporate development strategy is geared towards the long haul.

*Maria Schechtel*

Maria Schechtel  
President



# PRODUCT FINDER

THE RIGHT COMBINATION OF WORKING LENGTH, BENDING CAPACITY AND CONTROL SYSTEM TYPE WILL HELP YOU FIND THE APPROPRIATE MACHINE.

## 1. WHAT MATERIAL TYPES AND THICKNESSES DO YOU MOSTLY PROCESS?

## 2. WHICH SHEET LENGTHS DO YOU MAINLY WANT TO PROCESS?

## 3. HOW MANY OF YOUR PROCESS STEPS DO YOU WANT TO AUTOMATE?

## 4. WHAT IS YOUR PRODUCTION FOCUSED ON?

- Sheet metal jobs requiring more than manual bending  
...→ go smart and get motorized: **MBM** (p. 4 – 5)
- Extensive sheet metal jobs for roofs and exteriors  
...→ we offer two solid efficiency packages: **MAX + MAB** (p. 8 – 9), **MAX-F** (p. 10)
- Complex profiles and more industrially oriented work  
...→ here you'll find your powerful speedmasters: **MAF** (p. 11), **MAZ + MAE** (p. 14 – 15)

Machine type	MBM			MAX + MAX-F			MAB			MAF			MAZ			MAE					
	Steel 400 N/mm <sup>2</sup>	Aluminum 250 N/mm <sup>2</sup>	Stainless steel 600 N/mm <sup>2</sup>	Steel 400 N/mm <sup>2</sup>	Aluminum 250 N/mm <sup>2</sup>	Stainless steel 600 N/mm <sup>2</sup>	Steel 400 N/mm <sup>2</sup>	Aluminum 250 N/mm <sup>2</sup>	Stainless steel 600 N/mm <sup>2</sup>	Steel 400 N/mm <sup>2</sup>	Aluminum 250 N/mm <sup>2</sup>	Stainless steel 600 N/mm <sup>2</sup>	Steel 400 N/mm <sup>2</sup>	Aluminum 250 N/mm <sup>2</sup>	Stainless steel 600 N/mm <sup>2</sup>	Steel 400 N/mm <sup>2</sup>	Aluminum 250 N/mm <sup>2</sup>	Stainless steel 600 N/mm <sup>2</sup>			
Working length																					
1040																					
1540																					
2040							3.00	4.50	2.00							3.50	5.50	2.25	4.00	6.00	2.50
2540	1.00	1.50	0.60	2.00	3.00	1.25	2.50	3.50	1.50	2.50	3.50	1.50	3.00	4.50	2.00	3.50	5.00	2.25			
3100	1.00	1.50	0.60	1.50	2.00	1.00	2.00	3.00	1.25	2.00	3.00	1.25	2.50	4.00	1.50	3.00	4.50	2.00			
4040				1.00	1.50	0.60	1.50	2.00	1.00	1.50	2.00	1.00	1.75	2.50	1.00	2.00	3.00	1.25			
Control systems	ECT			ST			ECT			CNC S-TOUCH			CNC S-TOUCH								

**ST** **ST CONTROL**  
save profile sets in tables and repeat bending sequences with precision

**ECT** **ECT CONTROL**  
save profile sets in tables and repeat bending sequences with precision

**CNC S-TOUCH** **CNC S-TOUCH**  
full control of bending result and work processes

- includes control of motorized backgauge

- visual control of all bending sequences and machine functions
- intuitive profile-drawing on the touch-sensitive graphics monitor
- optional: PC offline software for creating and editing profiles on the PC

💡 Important to note when making your decision:  
Your choice of control system does not affect the model's bending performance.

# GO SMART AND GET MOTORIZED!

WHERE MANUAL BENDING MACHINES REACH THEIR LIMITS, THE **MBM** PROVIDES A HUGE INCREASE IN FUNCTIONALITY AND EFFICIENCY.

## MORE PRECISION. MORE TIME SAVED. MORE CONVENIENCE.

- work more professionally – produce entire profiles in one operation and repeat the process with precision at any time
- retrievable output values – continuous precision: thin-sheet processing for small batch production and recurring single-piece production
- efficient operability – single-user operation and monitor control make production conveniently simple

The ability to design profiles on a monitor offers full control of the machine functions and bending results.

Storing profiles electronically does away with paper documentation. The organized display of profile data in table format allows even complex profiles to be easily reproduced.

Simply load the profile data on the monitor and you're ready to go. The **MBM ECT** is your easy-to-use workhorse for consistently accurate bending results and high efficiency.

## BENEFITS

### AREAS OF APPLICATION

Thin-sheet processing for steel up to 1 mm thick, small batch and recurring single-piece production.

### VERY EASY TO OPERATE

- designed for smooth and efficient one-man operation
- produce an entire profile in less time with just one cycle
- easy-to-understand visual user guidance
- low training time and consistently high bend quality, even for varying operating personnel
- manually adjustable crowning – configure bending precision for material strength and thickness

### DURABLE MACHINE VALUE

- wear-free and maintenance-free direct eccentric drive (no gear wheels, no chains)
- soft start of bending beam and backgauge
- space-saving design and Schechtl's sturdy, proven welded construction with optimally sized beam elements

## TECHNICAL FEATURES

### MACHINE DATA

- working length of 2,540 mm and 3,100 mm
- capacity  
1.00 mm steel (400 N/mm<sup>2</sup>)  
1.50 mm aluminum (250 N/mm<sup>2</sup>)  
0.60 mm VA (600 N/mm<sup>2</sup>)
- easy-to-operate manual lowering of the bending beam
- adjustable crowning for maximal bending precision
- opening height of 130 mm
- considerable space at the clamping beam
- manual crowning of the bending beam
- space-saving location of electrical cabinet under the backgauge

### BACKGAUGE

- motorized backgauge 6 - 750 mm
- 3/10 mm precision
- 6 backgauge fingers with safety device

## CONTROL SYSTEM

### ACCURATE REPRODUCIBILITY OF PROFILE QUALITY

- saving profile data and bending sequences in organized tables expedites planning and the manufacturing process
- profile data and bending sequences available at any time: save once, retrieve as often as you like
- copy and individually customize profile sets for new orders

- **ECT** – the most affordable option for switching to electronically controlled profile manufacturing
- decreased setup time – frees up valuable time for production
- inputs for bending angle, backgauge measure, lifting height, hemming and cut
- space for 250 saved profile sets
- 36 bending angles can be saved for each profile set

The **MBM** is available with the following control system:

**ECT CONTROL**  
save profile sets and repeat bending sequences with precision

Control system details on p. 16 - 17

# MBM



Bending beam adjustment

Opening height of 130 mm

Space-saving electrical cabinet location

Motorized backgauge

RSL Roller Shear





# THERE'S WORK TO BE DONE ON ROOFS AND EXTERIORS

MBM, MAX AND MAB ARE MADE FOR THE JOB. MAKING SURE YOU'RE ALWAYS ON TOP.

*Traditional seamed profiles on church roof in tip top shape*



*The chimney cap will look great! The chimney sweep's going to be happy...*



*Perfectly fitting gutters for those days when it's pouring buckets*



MBM



MAX



MAB



MAX-F



MAF



*Too bad something this beautiful can only be seen from above*





# TWO EFFICIENCY PACKAGES FOR ROOFS AND EXTERIORS

TWO TRUE EFFICIENCY PACKAGES. **MAX** AND **MAB** ARE IN THE ELITE CLASS OF MOTORIZED BENDING MACHINES, MAKING SURE YOU'RE ALWAYS AT THE FOREFRONT.

## STRONG. FAST. EXTREMELY EFFICIENT.

- two classic long-distance specialists offering decades of endurance and a high return on investment
- extremely productive, will tackle any metalworking challenge with speed and precision
- deliver reliably perfect results on roofs and exteriors for all typical sheet thicknesses

**MAX** and **MAB** are favorites among sheet metal workers and exterior contractors. This duo can handle a majority of all demands for sheet metal bending. A smart choice for guaranteed long-term success.

## BENEFITS

### MORE ORDERS IN LESS TIME

- strong performance under various single-piece production specifications
- ideal for heavy workloads, investment pays for itself quickly

### A LITTLE OIL EVERY NOW AND THEN DOES THE TRICK

- minimal maintenance work required, mechanical direct drive with no hydraulic components
- totally wear-free bending beam and adjustable clamping beam

### EXTREMELY EASY OPERATION

- incredibly simple startup: Set it up, plug it in, and you're on your way!
- single-user operation results in real time savings
- movable foot switch is always in the right position
- bending beam's soft start protects valuable surfaces

## TECHNICAL FEATURES

### GETS TOP MARKS FOR PERFORMANCE AND SPEED

- offers very high bending capacity while keeping energy costs low
- impressively short bending times thanks to an incredible swivel speed of 90 °/s and a 50 mm/s opening speed for the clamping beam
- faster bending process: if bending angle is less than 90°, the clamping beam opens simultaneously
- high degree of production for sheet profiles on machines with control system and motorized backgauge

### DUAL ECCENTRIC SETS THE STANDARD FOR STABILITY AND BENDING PERFORMANCE

- stable drive thanks to the solid welded construction and highly rigid beam components
- **MAX**: bends sheet steel thicknesses up to 1.5 mm (at 3,100 mm)
- **MAB**: bends aluminum thicknesses up to 3 mm (at 3,100 mm)

## CONTROL SYSTEM

### VERSATILITY IN EVERY CONTROL SYSTEM

- **CNC S-Touch**: high-resolution touch-sensitive color display, intuitive profile creation with profile-drawing, sizing, and bending-sequence setting all by fingertip, includes control of all machine functions
- optional: PC offline software for creating and editing profiles on the PC
- **ECT**: save and retrieve profile sets in tables, includes direct control of the motorized backgauge
- **ST** control, save profile sets in tables and repeat bending sequences with precision

The machines **MAX** and **MAB** are available with the following control systems:

**CNC S-TOUCH**  
full control of bending results and work processes

**ECT CONTROL**  
save profile sets in tables and repeat bending sequences with precision

**ST CONTROL**  
save profile sets in tables and repeat bending sequences with precision

Control system details on p. 16-17

# MAX POWER



# MAB MORE POWER





# FASCINATING BENDING FREE SPACE

WITH THE **MAX-F** AND **MAF** YOU CAN CREATE PROFILES THAT ARE DIFFICULT OR IMPOSSIBLE TO PRODUCE ON OTHER MACHINES.



The **F-Geometry** is a special bending beam which enables the production of almost all profiles of the modern sheet metal trade.



## BENEFITS

### MORE FREE SPACE

- more bending free space = more space for profile geometries
- 14 mm free space behind the pivot point
- no special tools required

### MORE SAFETY

- low risk of collision on the bending beam
- great insertion free space = higher safety

### MORE SUCCESS

- make new business areas
- realize new challenges

### XXL-free space

With a 24 mm insert rail, a bending free space of 38 mm is achieved in the extended lower area.

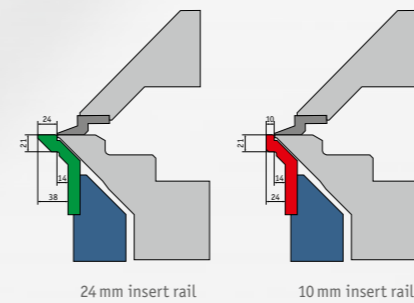

## CONTROL SYSTEM

### VERSATILITY IN EVERY CONTROL SYSTEM

- **CNC S-Touch:** high-resolution touch-sensitive color display, intuitive profile creation with profile-drawing, sizing, and bending-sequence setting all by fingertip, includes control of all machine functions
- optional: PC offline software for creating and editing profiles on the PC
- **ECT:** save and retrieve profile sets in tables, includes direct control of the motorized backgauge

The machines **MAX-F** and **MAF** are available with the following control systems:

**CNC S-TOUCH**  
full control of bending results and work processes

**ECT CONTROL**  
save profile sets in tables and repeat bending sequences with precision

Control system details on p. 16-17

The **MAX-F** is ideal for extensive sheet metal jobs.

The **MAF** is the right choice for complex profiles in the industrially oriented sheet metal trade.

# MAX-F POWER



# MAF MORE POWER





# PRESERVE THE TRADITIONAL, CREATE THE INNOVATIVE

MAZ AND MAE, YOUR FIRST CHOICE FOR COMPLEX DEMANDS  
IN LIGHT METAL AND EXTERIOR CONSTRUCTION.

*Precision wall covers  
are the best way to  
protect traditional and  
modern accents*

*Top-notch craftsmanship:  
With this exterior, the master  
outshines the competition*

*Metalworkers love  
reproducing the best  
parts in series*

*Real beauty is  
on the outside...  
the metalworker  
makes it possible*

MAZ



MAE





# LIGHTNING-FAST SPEED. OUTSTANDING POWER. MAXIMUM VERSATILITY.

**MAZ** AND **MAE** STAND FOR PEAK PERFORMANCE  
IN TWO PROVEN CONSTRUCTION AREAS.

## INCREDIBLE PRODUCTIVITY WITH DIFFERENT TOOL SYSTEMS

- the team with exceptional versatility to meet the challenge of variable customer needs
- focused on three fundamental strengths: increasing versatility – enhancing the performance range – expediting order flows
- two powerful machines with a compact design deliver top results, reliably and at a series-production pace

With their individual performance classes, **MAZ** and **MAE** are the ideal equipment to handle particularly high-end jobs in your production lineup.

### ECCENTRIC DRIVE

The **MAZ** is the most powerful and versatile machine in our lineup of eccentric-drive machines.

### SPINDLE DRIVE

With its powerful spindle drive, only the **MAE** offers greater performance.

## BENEFITS

### MAIN AREAS OF APPLICATION

- industrially oriented metalworking trade
- specific, complex requirements in light metal and exterior construction
- series and contract production

### TOP MARKS FOR VERSATILITY, CONVENIENCE AND EFFICIENCY

- the most versatile and efficient motorized bending machines in their classes
- easy retrofitting of special tools at any time for individual customer specifications and that with just one operator
- adjustment-free material changes, automatic configuration of sheet thickness saves time
- minimal setup times expedite the flow of orders

## TECHNICAL FEATURES

### SETTING THE STANDARD FOR PRECISION AND BEND QUALITY

- extremely fast bending process thanks to dynamic method using 5 machine positions
- Click System comes standard, use for individual tool mounts
- optional tool-free changeover to segment-bending for box and pan shapes
- high stability with clamping beam driven from both sides
- consistent bending precision across the entire workpiece length, even for thick sheets
- solid, wear-free welded construction ensures machine durability, even under continuously high loads

## CONTROL SYSTEM

### INTUITIVE PROFILE CREATION WITH CNC S-TOUCH

- touch to create: profile-drawing by fingertip on the touch-sensitive monitor
- dimension and sequence profiles in record time
- control of all machine functions with precision reproducibility
- dynamic control of up to 5 axes enables high order throughput
- optional: PC offline software for creating and editing profiles on the PC

The machines **MAZ** and **MAE** are available with the following control system:

**CNC S-TOUCH**  
full control of bending results and work processes

Control system details on p. 16-17

# MAZ ECCENTRIC



# MAE SPINDLE





# CONTROL SYSTEMS

HOW MANY OF YOUR PROCESS STEPS DO YOU WANT TO AUTOMATE?  
YOUR NEED FOR VERSATILITY AND PRECISION  
DETERMINES YOUR DEGREE OF CONTROL CONVENIENCE.

 Important to know: The choice of control system does not affect the bending capacity of the machine model.

CNC  
S-TOUCH

## CNC S-TOUCH

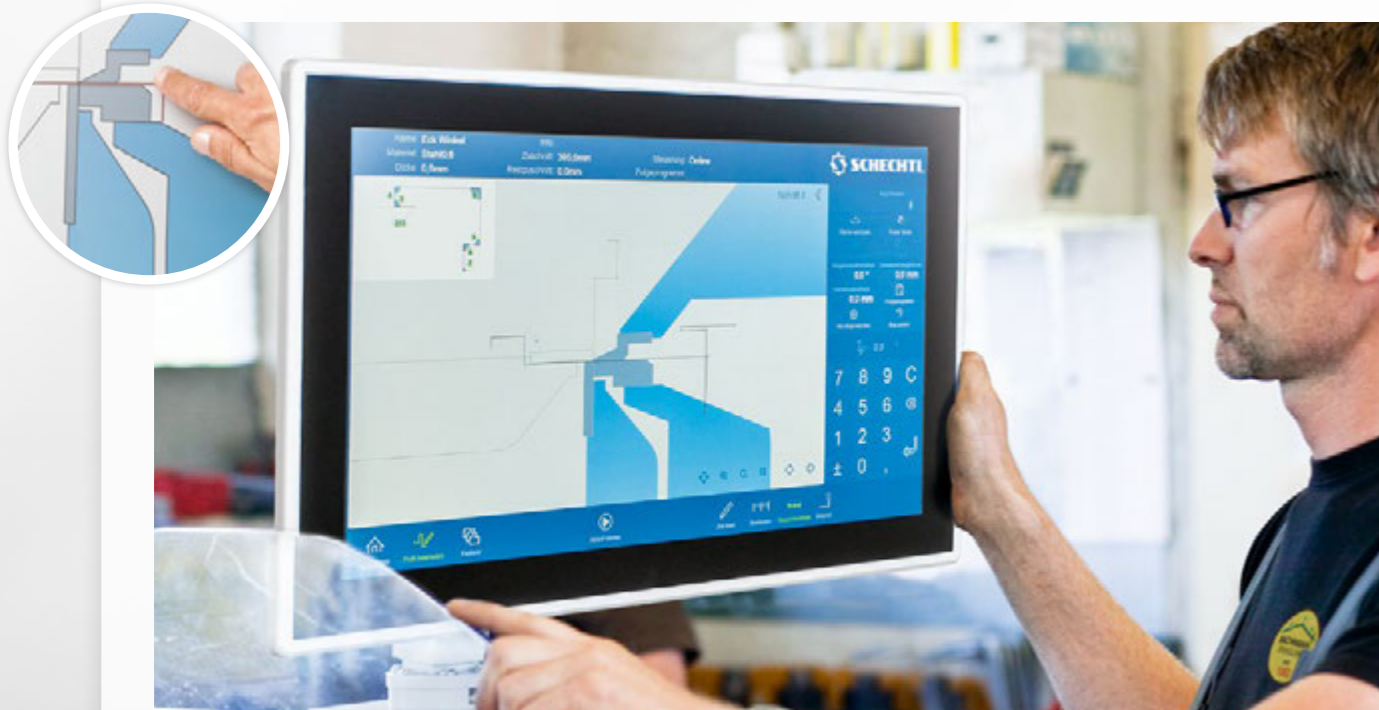

### INTUITIVE. EASY. FASTER. FROM PROFILE CONCEPT TO BENDING PRECISION IN RECORD TIME

- convenient production center – draw and implement complex bending sequences with your fingertips
- virtual laboratory – develop, test and correct profile ideas intuitively, without using a single workpiece
- electronic notebook – document and save conceptual drawings on the fly and retrieve at any time

### TOUCH TO CREATE – HARD TO BELIEVE HOW REVOLUTIONARY THE SPEED AND SIMPLICITY ARE!

Creating new profiles with **CNC S-Touch** is easier than using a smartphone. There are only two requirements: Your conceptual drawing of the finished profile and a fingertip.

**STEP 1** Draw your profile sketch on the touch-sensitive monitor using your fingertip; don't worry about exact lengths or angles yet.

**STEP 2** Now size the exact lengths and radii. You can specify the bend sequencing with the simple tap of a finger.

**STEP 3** Test the bending sequence without using a single workpiece. On the monitor, you'll see your profile concept turn into bending precision. If everything looks good, you can begin production.

**START** That's it, you're ready to go! **CNC S-Touch** automatically recognizes how to rotate, flip and reset the workpiece and also what tools are required.

ECT

## ECT CONTROL



### DECREASED SETUP TIME – FREES UP VALUABLE TIME FOR PRODUCTION

- ideal for small batch and recurring single-piece production in the metalworking trade
- saving and loading the profile data in tables speeds up the production process
- ideal for smaller metalworking jobs
- save the profile data once and it's available any time
- copy completed profile sets and individually customize for new orders

#### HARDWARE

- very clear and modern 10.4" display
- fast and precise stop with servo drive in back gauge
- dynamic movement of the axes due to new control of the drives

#### SOFTWARE

- Look & Feel as usual with the Schechtel S-Touch control
- simple input of profiles
- additional functions such as bending beam dwell time, Teach-In of the bending beam
- material, profile and tool management in the local database or network database
- possibility to exchange profiles between the Schechtel CNC and EC(T)
- extensive diagnostic options
- remote maintenance options (fast and easy to understand)

ST

## ST CONTROL



- support rack (adjustable in depth) for easy positioning of large-sized metal sheets
- Comfortable operation, as usual from the Schechtel ECT



# S-TOUCH CONNECT DIGITALLY NETWORKED WORK PROCESSES

BENEFIT FROM THE DIGITALLY NETWORKED WORK PROCESSES FOR SHEET METAL WORKING AND THE MANAGEMENT OF YOUR PROJECTS.

PLANNING

## In the office. With PC software.

Project planning and order processing in every phase of work.

- ✔ Detailed simulation of profiles.
- ✔ Pre- and post-processing of profile data.

S-TOUCH PLAN

SEMA SOFTWARE

CAD software

Bendex



Data exchange:  
Up- and downloads

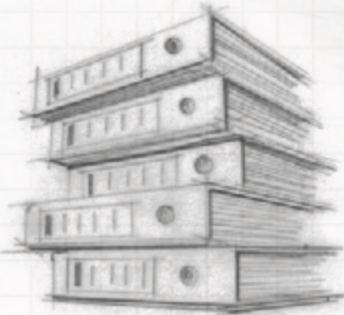

Data exchange:  
Up- and downloads

MANAGEMENT

## Digital storage location.

Enter, change and save orders and profiles at the construction site, in the office or in the machine.

- ✔ Data always current
- ✔ The networked documentation synchronizes production with planning

Company server

Cloud on the web

Data exchange:  
Up- and downloads

## At the construction site.

Using mobile end devices.

Profile and order entry on-site.

- ✔ Enter and send the required file format on-site.

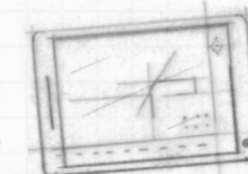

UIT smart & digital

Bendex

Other software solutions

## On your machine. Third-party product.

Exchange of profile data possible between any manufacturers.

- ✔ Access to all profile data.
- ✔ Directly entered profiles are available for the entire S-TOUCH CONNECT

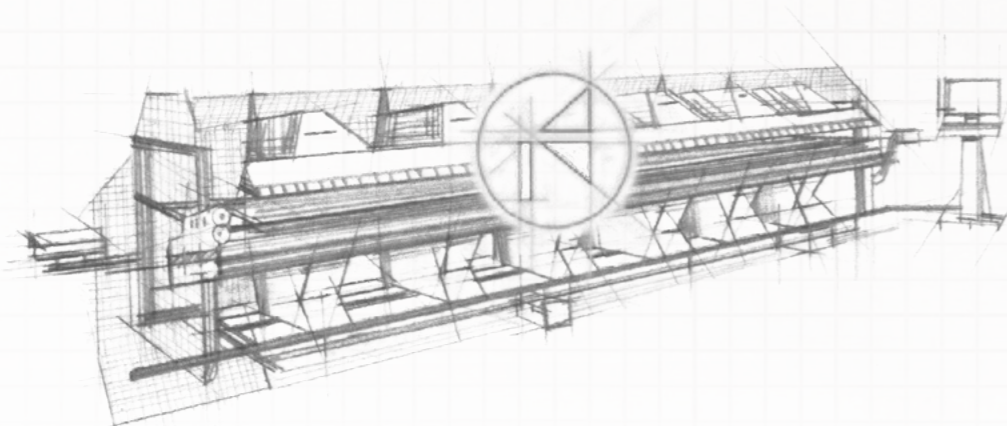

PRODUCTION.

## On your Schechtl machine. With S-TouchCNC control system.

Innovative machine control system: Create profile and bending sequences on the machine using the touch screen.

- ✔ Direct acquisition of profiles from planning, resulting in quicker production without sources of error

S-TOUCHCNC

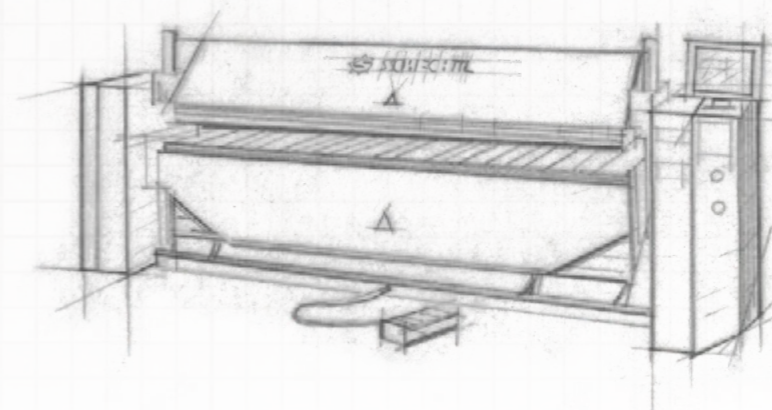



# PROFILE AND RETAINING CLAMP RAILS FOR MOTORIZED BENDING MACHINES

SHARP RAIL 66/24 20°

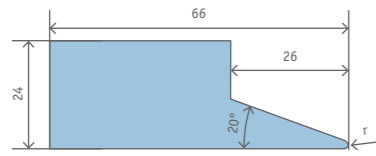

SHARP RAIL 66/24 20°, OFFSET

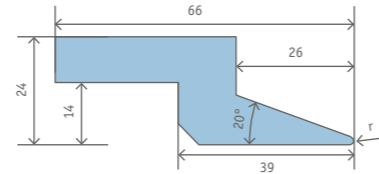

ROUND RAIL 66/24 R = 1.5 - 12

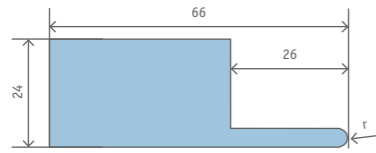

ROUND RAIL 66/24 WIDE, OFFSET

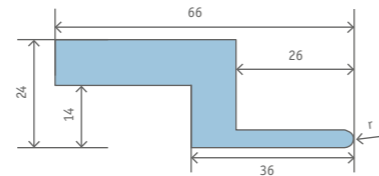

RETAINING CLAMP RAIL, 55 MM WITH SUPPORT RAIL

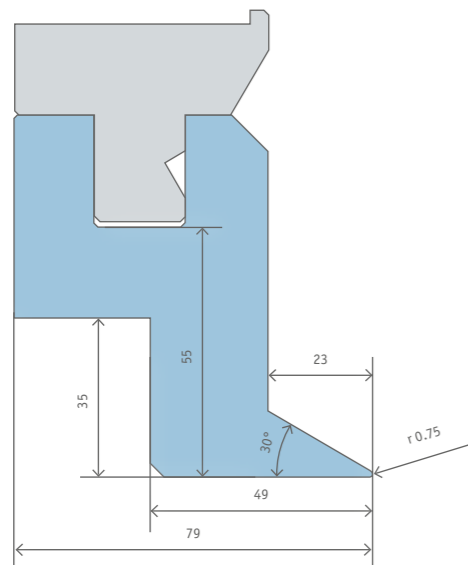

RETAINING CLAMP RAIL, 93 MM WITH SUPPORT RAIL

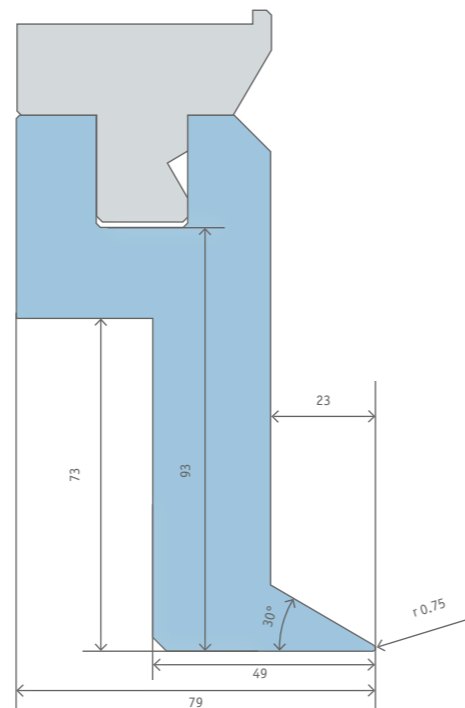

## CLICK SYSTEM

SHARP RAIL 20° R = 1 - 2 WITH CLICK SYSTEM

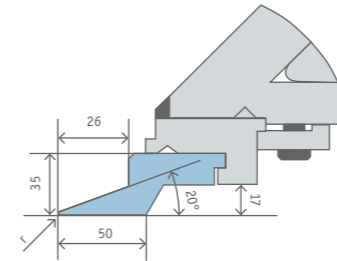

SHARP RAIL 45° R = 2 WITH CLICK SYSTEM

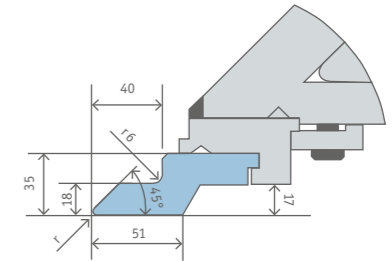

RETAINING CLAMP CLICK SYSTEM 107 MM, FREE AT FRONT

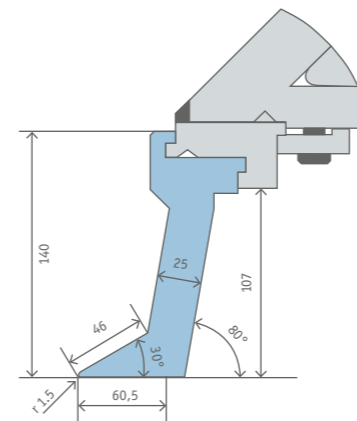

RETAINING CLAMP CLICK SYSTEM 107 MM, FREE AT REAR

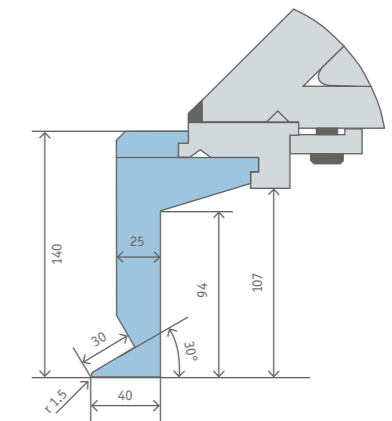

RETAINING CLAMP CLICK SYSTEM 157 MM, FREE AT FRONT

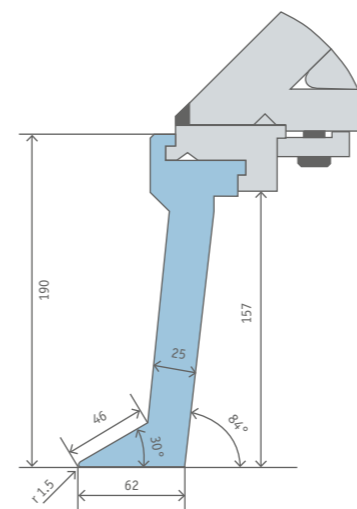

RETAINING CLAMP CLICK SYSTEM 157 MM, FREE AT REAR

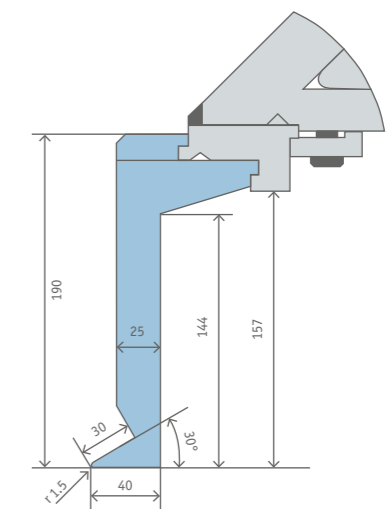



# TECHNICAL DATA

PERFORMANCE, DIMENSIONS AND WEIGHT.  
SECTIONAL DRAWINGS FOR BEAM ELEMENTS.

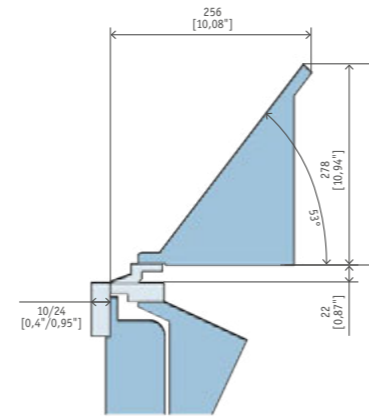

## MBM

### ECT CONTROL

Model		250	310
Working length	mm	2,500	3,100
Bending capacity			
Steel 400 N/mm <sup>2</sup>	mm	1.00	1.00
Aluminum 250 N/mm <sup>2</sup>	mm	1.50	1.50
VA 600 N/mm <sup>2</sup>	mm	0.60	0.60
Bending beam motor power rating	kW	0.55	0.55
Clamping beam motor power rating	kW	0.37	0.37
Max. opening height	mm	130	130
Clamping beam speed	mm/s	40	40
Bending beam speed	°/s	63	63
Overall dimensions			
Length	mm	3,325	3,825
Width with 750 mm motorized backgauge	mm	1,690	1,690
Working height	mm	931	931
Total height	mm	1,645	1,645
Weight	kg	1,700	1,860
Connecting data			
Connecting load	kVA	1.87	1.87
Recommended fuse protection EU 3 x slow blow	A	16	16
Connector plug CEE.. A 5-pole		16	16
Recommended RCD type	Doepke	DFS 4 B SK	
Recommended RCD tripping current	mA	30	30
supply voltage EU 3 x	AC 50 - 60 Hz	380 - 420	380 - 420

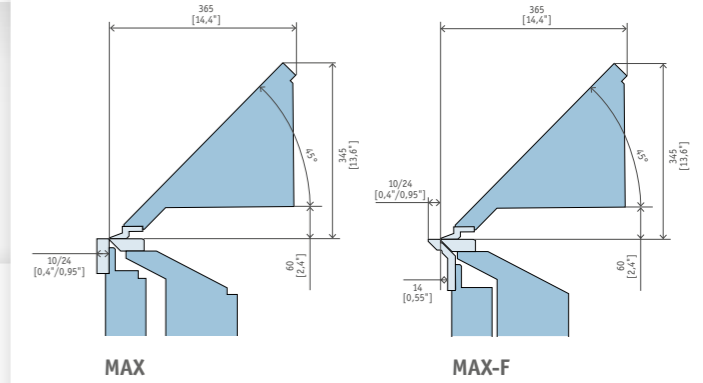

## MAX AND MAX-F

Model		250	310	400
Working length	mm	2,540	3,100	4,040
Bending capacity				
Steel 400 N/mm <sup>2</sup>	mm	2.00	1.50	1.00
Aluminum 250 N/mm <sup>2</sup>	mm	3.00	2.00	1.50
VA 600 N/mm <sup>2</sup>	mm	1.25	1.00	0.60
Bending beam motor power rating	kW	2.2	2.2	2.2
Clamping beam motor power rating	kW	0.75	0.75	0.75
Max. opening height	mm	140	140	140
Bending beam speed	°/s	90	90	90

### ST AND ECT CONTROL

Overall dimensions:		250	310	400
Length	mm	3,442	4,002	4,942
Width	mm	760	760	760
Width with 750 mm motorized backgauge (only ECT)	mm	1,588	1,588	1,588
Working height	mm	860	860	860
Total height	mm	1,260	1,260	1,260
Weight	kg	2,235	2,465	2,850
Connecting data				
Connecting load	kVA	4.27	4.27	4.27
Recommended fuse protection EU 3 x slow blow	A	16	16	16
Connector plug CEE.. A 5-pole		16	16	16
Recommended RCD type	Doepke	DFS 4 B SK		
Recommended RCD tripping current	mA	30	30	30
Supply voltage EU 3 x	AC 50 - 60 Hz	380 - 420	380 - 420	380 - 420

### CNC S-TOUCH CONTROL

Overall dimensions:		250	310	400
Length	mm	3,500	4,050	5,000
Width with 1,000 mm motorized backgauge	mm	1,903	1,903	1,903
Working height	mm	860	860	860
Total height	mm	1,674	1,674	1,674
Weight	kg	2,235	2,465	2,850
Connecting data				
Connecting load	kVA	4.64	4.64	4.64
Recommended fuse protection EU 3 x slow blow	A	16	16	16
Connector plug CEE.. A 5-pole		16	16	16
Recommended RCD type	Doepke	DFS 4 B SK		
Recommended RCD tripping current	mA	30	30	30
Supply voltage EU 3 x	AC 50 - 60 Hz	380 - 420	380 - 420	380 - 420



# TECHNICAL DATA

PERFORMANCE, DIMENSIONS AND WEIGHT.  
SECTIONAL DRAWINGS FOR BEAM ELEMENTS.

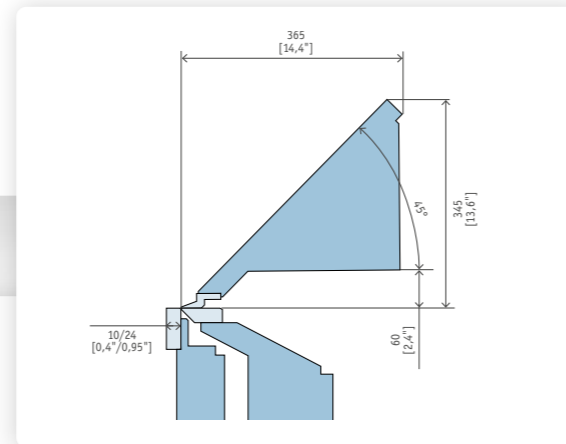

## MAB

Model		200	250	310	400
Working length	mm	2,040	2,540	3,100	4,040
Bending capacity					
Steel 400 N/mm <sup>2</sup>	mm	3.00	2.50	2.00	1.50
Aluminum 250 N/mm <sup>2</sup>	mm	4.50	3.50	3.00	2.00
VA 600 N/mm <sup>2</sup>	mm	2.00	1.50	1.25	1.00
Bending beam motor power rating	kW	1.5	1.5	1.5	1.5
Clamping beam motor power rating	kW	1.1	1.1	1.1	1.1
Max. opening height	mm	140	140	140	140
Bending beam speed	°/s	90	90	90	90

### ST AND ECT CONTROL

Overall dimensions: Length	mm	3,020	3,520	4,080	5,020
Width	mm	822	822	822	822
Width with 750 mm motorized backgauge (only ECT)	mm	1,633	1,633	1,633	1,633
Working height	mm	910	910	910	910
Total height	mm	1,300	1,300	1,300	1,300
Weight	kg	2,730	3,020	3,310	3,950

### ECT CONTROL

Connecting data					
Connecting load	kVA	5.37	5.37	5.37	5.37
Recommended fuse protection EU 3 x slow blow	A	16	16	16	16
Connector plug CEE.. A 5-pole		16	16	16	16
Recommended RCD type	Doepke	DFS 4 B SK			
Recommended RCD tripping current	mA	30	30	30	30
Supply voltage EU 3 x	AC 50 - 60 Hz	380 - 420	380 - 420	380 - 420	380 - 420

### CNC S-TOUCH

Overall dimensions: Length	mm	3,100	3,600	4,160	5,100
Width with 1,000 mm motorized backgauge	mm	1,810	1,810	1,810	1,810
Working height	mm	910	910	910	910
Total height	mm	1,750	1,750	1,750	1,750
Weight	kg	2,750	3,050	3,350	4,000
Connecting data					
Connecting load	kVA	5.74	5.74	5.74	5.74
Recommended fuse protection EU 3 x slow blow	A	16	16	16	16
Connector plug CEE.. A 5-pole		16	16	16	16
Recommended RCD type	Doepke	DFS 4 B SK			
Recommended RCD tripping current	mA	30	30	30	30
Supply voltage EU 3 x	AC 50 - 60 Hz	380 - 420	380 - 420	380 - 420	380 - 420

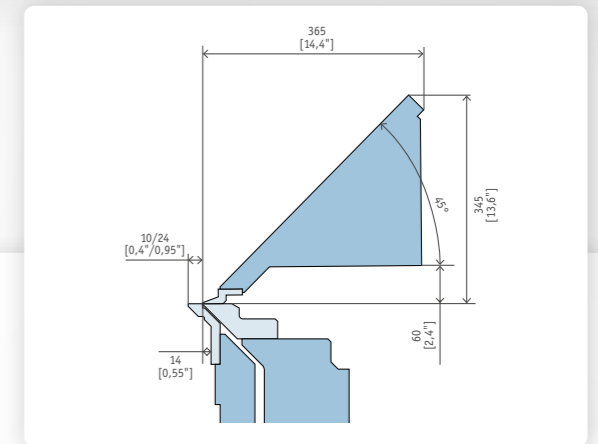

## MAF

### CNC S-TOUCH CONTROL

Model		250	310	400
Working length	mm	2,540	3,100	4,040
Bending capacity				
Steel 400 N/mm <sup>2</sup>	mm	2.50	2.00	1.50
Aluminum 250 N/mm <sup>2</sup>	mm	3.50	3.00	2.00
VA 600 N/mm <sup>2</sup>	mm	1.50	1.25	1.00
Max. opening height	mm	140	140	140
Overall dimensions: Length	mm	3,855	4,385	5,325
Width with 1000 mm motorized backgauge	mm	2,232	2,232	2,232
Working height	mm	950	950	950
Total height	mm	1,924	1,924	1,924
Weight	kg	3,400	4,070	5,000
Connecting data				
Connecting load	kVA	8.4	8.4	8.4
Recommended fuse protection EU 3 x slow blow	A	16	16	16
Connector plug CEE.. A 5-pole		32	32	32
Recommended RCD type	Doepke	DFS 4 SK		
Recommended RCD tripping current	mA	300	300	300
Supply voltage EU 3 x	AC 50 - 60 Hz	380 - 420	380 - 420	380 - 420



# TECHNICAL DATA

PERFORMANCE, DIMENSIONS AND WEIGHT.  
SECTIONAL DRAWINGS FOR BEAM ELEMENTS.

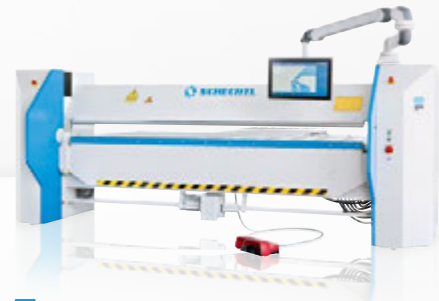

## MAZ

### CNC S-TOUCH CONTROL

Model		200	250	310	400
Working length	mm	2,040	2,540	3,100	4,040
Bending capacity					
Steel 400 N/mm <sup>2</sup>	mm	3.50	3.00	2.50	1.75
Aluminum 250 N/mm <sup>2</sup>	mm	5.00	4.50	4.00	2.50
VA 600 N/mm <sup>2</sup>	mm	2.25	2.00	1.50	1.00
Bending beam motor power rating	kW	2*2.2	2*2.2	2*2.2	2*2.2
Clamping beam motor power rating	kW	1.5	1.5	1.5	1.5
Power rating of motor for lowering of bending beam	kW	2*0.12	2*0.12	2*0.12	2*0.12
Max. opening height	mm	140	140	140	140
Max. opening height + spindle travel.	mm	155	155	155	155
Max. clamping beam speed	mm/s	56	56	56	56
Max. bending beam speed	°/s	90	90	90	90
Overall dimensions: Length	mm	3,350	3,850	4,600	5,350
Width with 1000 mm motorized backgauge	mm	2,200	2,200	2,200	2,200
Working height	mm	925	925	925	925
Total height	mm	2,150	2,150	2,150	2,150
Weight	kg	3,200	3,350	3,750	4,700
Connecting data					
Connecting load	kVA	8.4	8.4	8.4	8.4
Recommended fuse protection EU 3 x slow blow	A	16	16	16	16
Connector plug CEE.. A 5-pole		32	32	32	32
Recommended RCD type	Doepke	DFS 4 B SK			
Recommended RCD tripping current	mA	300	300	300	300
Supply voltage EU 3 x	AC 50 - 60 Hz	380 - 420	380 - 420	380 - 420	380 - 420

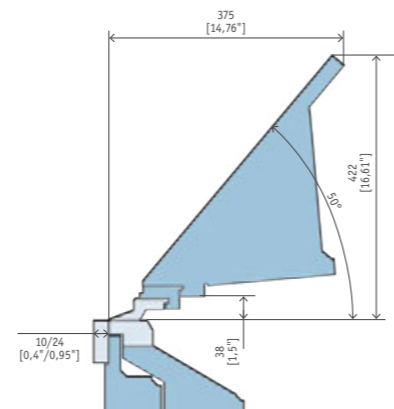

## MAE

### CNC S-TOUCH CONTROL

Model		200	250	310	400
Working length	mm	2,040	2,540	3,100	4,040
Bending capacity					
Steel 400 N/mm <sup>2</sup>	mm	4.00	3.50	3.00	2.00
Aluminum 250 N/mm <sup>2</sup>	mm	6.00	5.00	4.50	3.00
VA 600 N/mm <sup>2</sup>	mm	2.50	2.25	2.00	1.25
Bending beam motor power rating	kW	2*1.5	2*1.5	2*1.5	2*1.5
Clamping beam motor power rating	kW	4	4	4	4
Power rating of motor for bending beam lowering	kW	2*0.12	2*0.12	2*0.12	2*0.12
Max. opening height	mm	225	225	225	225
Max. clamping beam speed	mm/s	20	20	20	20
Max. bending beam speed	°/s	70	70	70	70
Overall dimensions: Length	mm	3,190	3,690	4,250	5,190
Width with 1000 mm motorized backgauge	mm	1,790	1,790	1,790	1,790
Working height	mm	900	900	900	900
Total height	mm	2,150	2,150	2,150	2,150
Weight	kg	3,500	3,900	4,300	5,000
Connecting data					
Connecting load	kVA	8.4	8.4	8.4	8.4
Recommended fuse protection EU 3 x slow blow	A	16	16	16	16
Connector plug CEE.. A 5-pole		16	16	16	16
Recommended RCD type	Doepke	DFS 4 B SK			
Recommended RCD tripping current	mA	300	300	300	300
Supply voltage EU 3 x	AC 50 - 60 Hz	380 - 420	380 - 420	380 - 420	380 - 420

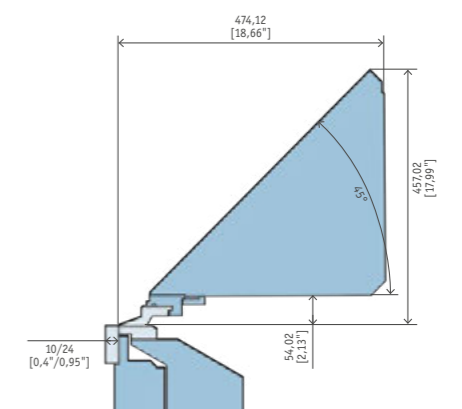















# LINE-UP OF MACHINES

MACHINES FOR THE ENTIRE  
RANGE OF TOP-QUALITY METALWORKING  
AS OF 01/2022

## MANUAL BENDING MACHINES

 <p><b>TBX</b></p> <ul style="list-style-type: none"> <li>Single-user lightweight for the job site</li> <li>Max. portability, solid, ready to use in 2 min</li> <li>Unique X stand, foldable, on wheels</li> </ul>	 <p><b>LBT</b></p> <ul style="list-style-type: none"> <li>Construction convenience: bending, cutting, beading</li> <li>Portable, wheel locks, smooth-running</li> <li>Versatile options for clamping beam rail</li> </ul>	 <p><b>LBX</b></p> <ul style="list-style-type: none"> <li>Compact and powerful on-site bending</li> <li>Pretensioning for material type and thickness</li> <li>Optimal bending result across the working width</li> </ul>	 <p><b>TBS</b></p> <ul style="list-style-type: none"> <li>Smart segment-bending at the job site</li> <li>Tool-free adjustment, many fold shapes</li> <li>Unique X stand, light, max. portability</li> </ul>
 <p><b>UK</b></p> <ul style="list-style-type: none"> <li>Smart segment-bending, proven 10,000 times</li> <li>Combine elements without tools</li> <li>Foot pedal, frees up hands for positioning</li> </ul>	 <p><b>UKV</b></p> <ul style="list-style-type: none"> <li>Segment-bending even more powerful/versatile</li> <li>Fast and tool-free segment adjustment</li> <li>Hands stay free for precision positioning</li> </ul>	 <p><b>UKF</b></p> <ul style="list-style-type: none"> <li>Segment bending of large special forms</li> <li>Extra high standards for use – XXL freedom</li> <li>Maximum flexibility, highest comfort</li> </ul>	 <p><b>KS</b></p> <ul style="list-style-type: none"> <li>Incredibly versatile, fast, cost-effective</li> <li>Easy and convenient for creative profiles</li> <li>World's best-selling swivel bending machine</li> </ul>
 <p><b>KSV</b></p> <ul style="list-style-type: none"> <li>Award-winning, cost-effective, versatile</li> <li>Handles many materials and thicknesses</li> <li>Produces remarkable profiles</li> </ul>	 <p><b>HBM</b></p> <ul style="list-style-type: none"> <li>Special profiles only possible here</li> <li>Precise positioning of workpieces</li> <li>Simple lowering of bending beam</li> </ul>	 <p><b>HA</b></p> <ul style="list-style-type: none"> <li>Sturdy package for single-user operation</li> <li>Specially designed for thick sheets</li> <li>Ideal configuration for recurring bends</li> </ul>	 <p><b>SB50</b></p> <ul style="list-style-type: none"> <li>For the production of roof and facade shingles</li> <li>Only one work step for two 180° edges</li> <li>Time saving of approx. 70 %</li> </ul>

## MOTORIZED BENDING MACHINES

 <p><b>MBM ECT</b></p> <ul style="list-style-type: none"> <li>Smart move to motor and monitor system</li> <li>Precision reproduction of complex profiles</li> <li>Single-user operation, sturdy, time-efficient</li> </ul>	<p>MAX STD MAX ECT MAX CNC S-Touch</p>  <p><b>MAX</b></p> <ul style="list-style-type: none"> <li>Motorized model with best custom versatility</li> <li>Sturdy construction, high bending capacity</li> <li>The classic for 90% of all bending jobs</li> </ul>	<p>GEOMETRY</p> <p>MAX-F ECT MAX-F CNC</p>  <p><b>MAX-F</b></p> <ul style="list-style-type: none"> <li>Maximum bending free space</li> <li>14 mm free space behind the pivot point</li> <li>More space for profile geometries</li> </ul>	<p>MAB STD MAB ECT MAB CNC S-Touch</p>  <p><b>MAB</b></p> <ul style="list-style-type: none"> <li>More power than MAX, better performance</li> <li>Powerful machine for roofs and exteriors</li> <li>Sturdy construction, minimal maintenance</li> </ul>
 <p><b>MAZ CNC</b></p> <ul style="list-style-type: none"> <li>Best in series production and light metal</li> <li>Speed king: outstanding productivity</li> <li>Shortest setup times, rapid bending sequences</li> </ul>	 <p><b>MAE CNC</b></p> <ul style="list-style-type: none"> <li>Economical in the industrial trade</li> <li>Most adaptable changeover system / 1-click</li> <li>Minimal setup times, versatile, compact</li> </ul>	<p>GEOMETRY</p>  <p><b>MAF CNC</b></p> <ul style="list-style-type: none"> <li>Maximum bending free space – without special tools</li> <li>14 mm free space behind the pivot point</li> <li>Low risk of collision on the bending beam</li> </ul>	



## MANUAL SHEARS



**HT**

- Resiliently sturdy: lasts for generations
- Single-user operation, economical precision
- Space-saving, maintenance-free, lots of accessories

## MOTORIZED SHEARS

<p>SMT BV SMT BVH SMT NC SMT NCH</p>  <p><b>SMT</b></p> <ul style="list-style-type: none"> <li>Smallest 3-meter motorized squaring shear</li> <li>For thin sheets to strong materials</li> <li>Saves energy, space and time</li> </ul>	<p>MSB BV MSB BVH MSB NC MSB NCH</p>  <p><b>MSB</b></p> <ul style="list-style-type: none"> <li>Small size of SMT with much more power</li> <li>Even more performance in single-user operation</li> <li>The powerful and cost-effective choice</li> </ul>	<p>MSC BV MSC BVH MSC NC MSC NCH</p>  <p><b>MSC</b></p> <ul style="list-style-type: none"> <li>The pro for thin sheets and exterior work</li> <li>Two motors, equal power distribution</li> <li>High efficiency, min. energy consumption</li> </ul>
--	--	---

## SHEARS FOR CUT-TO-LENGTH LINE SYSTEMS



**MT**

- Integrated automatic shearing system
- For continuous operation in the production process
- Individually adaptable, minimal maintenance



**ST**

- Shearing system with best configurability
- Integration into serial production equipment
- For many other materials besides sheet metals

## MODULAR COIL-HANDLING



**MCH**

- Metal sheets are always available
- Modular design
- Customizable

## PROFILING MACHINES



**SZP**

- Extra-long and very solid in ventilation work
- Straight-line profiling without distortion
- High operating cycle speed



## PLANNING / NOTES

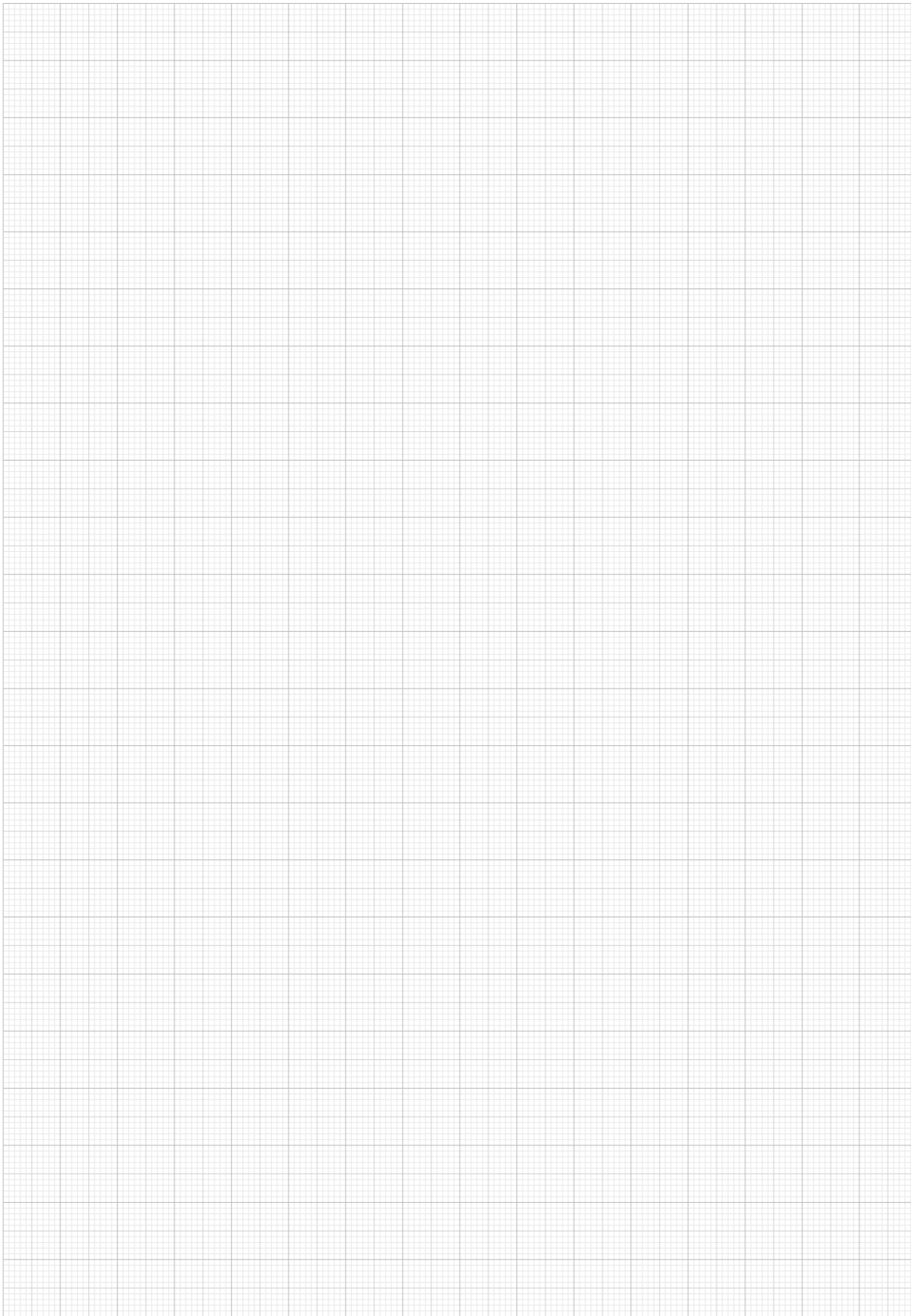

## PLANNING / NOTES

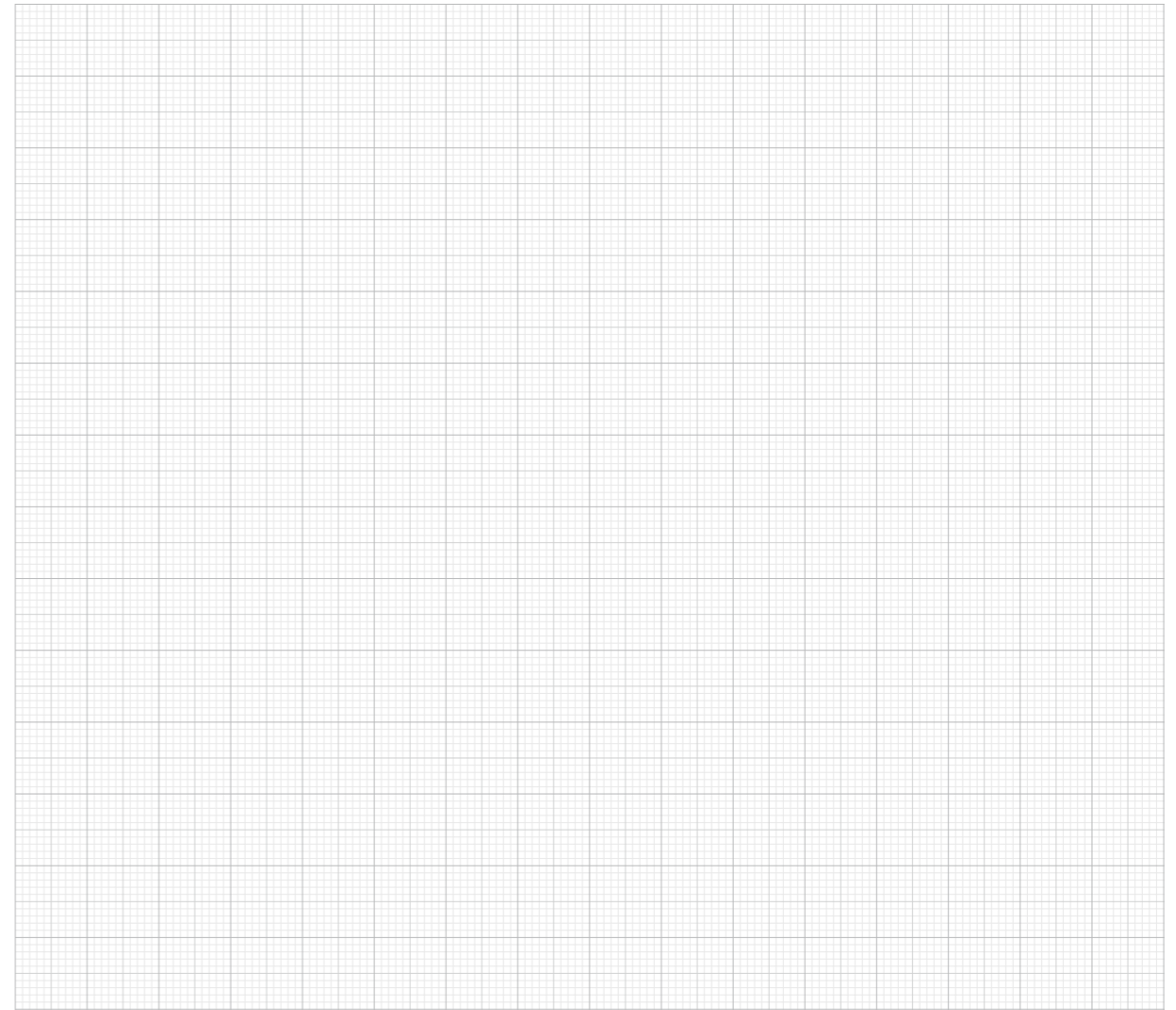

## FURTHER PRODUCT INFORMATION



[www.schechtel.de](http://www.schechtel.de) 





www.Djermester.de www.Arrisma.de

**Schechtl Maschinenbau GmbH**

Viehhauser Straße 4  
83533 Edling

Tel +49 8071-5995-0  
Fax +49 8071-5995-99

info@schechtl.de  
www.schechtl.de

www.schechtl.de

